

- △ HOUSING—MATERIAL : LIQUID-CRYSTAL-POLYMER.
- △ CONTACT—MATERIAL : PHOS. BRONZE.
- △ LATCH—MATERIAL : BRASS, NICKEL PLATE.
- △ CONTACT—PLATE: 0.00508[.000200] MIN. TIN/LEAD OVER 0.00127 [.000050] MIN NICKEL.
- 5. IN ADDITION TO THOSE RECOMMENDED "SIMM" P.C. BOARD DIMENSIONS AND TOLERANCES SHOWN, ALL JEDEC SPECIFICATIONS APPLY AS SHOWN ON MO-116, ISSUE A.
- 6. RECOMMENDED MATING S.I.M.M. TAB METALLURGY:  
 BASE METAL—COPPER. PLATING TO BE 0.00762[.000300] MIN TIN/LEAD OVER 0.00127[.000050] MIN NICKEL.
- △ OBSOLETE
- △ DATE CODE: (YEAR WEEK) XXXX FORMAT, LOCATED APPROXIMATELY AS SHOWN ON OPPOSITE SIDE.

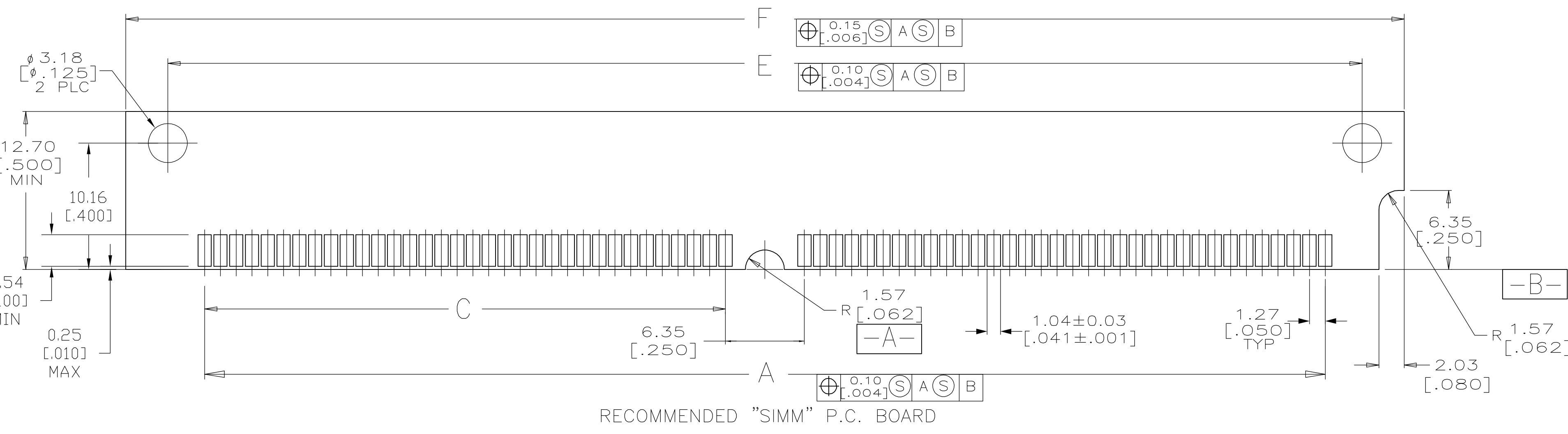
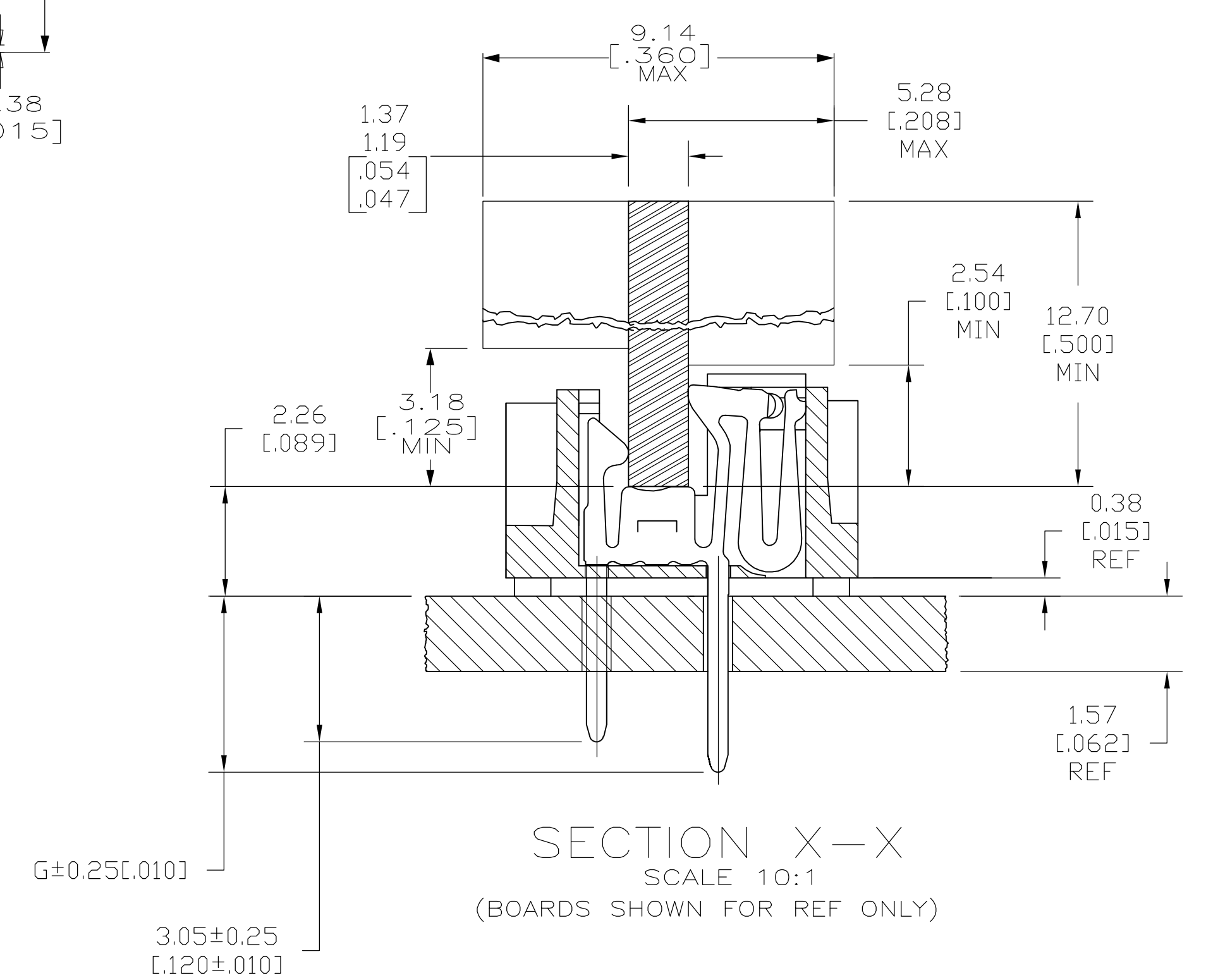
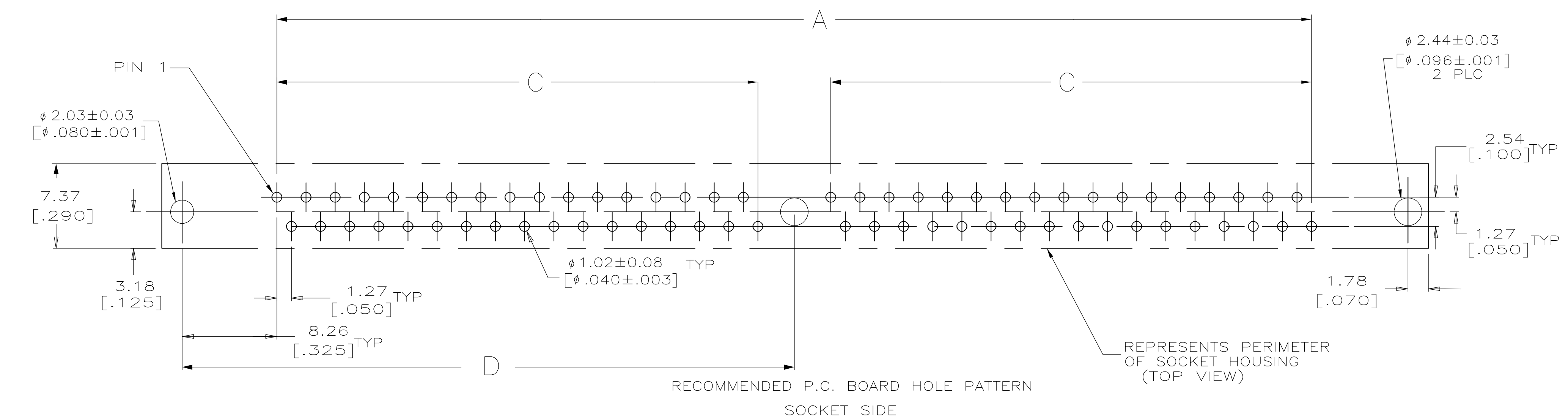
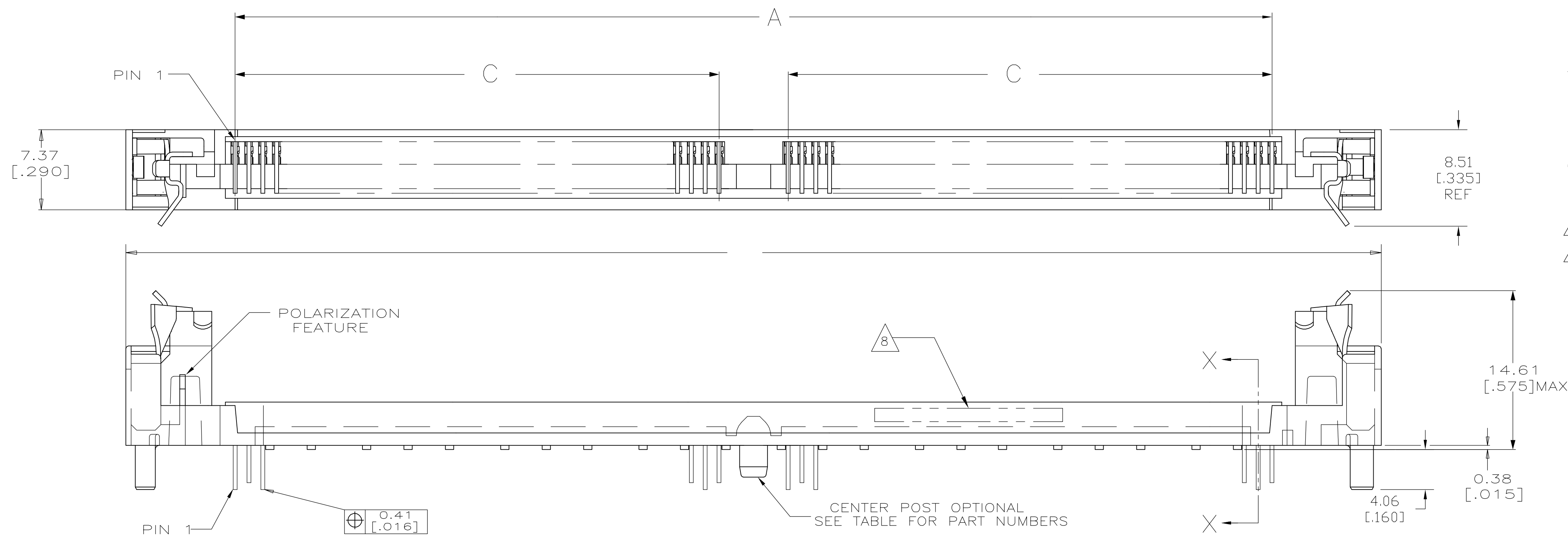

	G	F	E	D	C	B	A	NO OF POSN	PART NO
WITH CENTER POST	3.05[.120]	107.95[4.250]	101.19[3.984]	55.88[2.200]	44.45[1.750]	115.57[4.550]	95.25[3.750]	72	3-822030-3
W/OUT CENTER POST	3.68[.145]	67.31[2.650]	60.55[2.384]	35.56[1.400]	24.13[.950]	74.93[2.950]	54.61[2.150]	40	△ 822030-6
	3.68[.145]	67.31[2.650]	60.55[2.384]	35.56[1.400]	24.13[.950]	74.93[2.950]	54.61[2.150]	40	△ 822030-5
	3.68[.145]	118.11[4.650]	111.35[4.384]	60.96[2.400]	49.53[1.950]	125.73[4.950]	105.41[4.150]	80	822030-4
WITH CENTER POST	3.68[.145]	107.95[4.250]	101.19[3.984]	55.88[2.200]	44.45[1.750]	115.57[4.550]	95.25[3.750]	72	822030-3
	3.68[.145]	102.87[4.050]	96.11[3.784]	53.34[2.100]	41.91[1.650]	110.49[4.350]	90.17[3.550]	68	△ 822030-2
	3.68[.145]	97.79[3.850]	91.03[3.584]	50.80[2.000]	39.37[1.550]	105.41[4.150]	85.09[3.350]	64	△ 822030-1

THIS DRAWING IS A CONTROLLED DOCUMENT.

DIMENSIONS: mm [INCHES]	TOLERANCES UNLESS OTHERWISE SPECIFIED:	DIN S. WAITMAN	APVD M.YFOMANS	tyco Electronics	Tyco Electronics Corporation Harrisburg, PA 17105-3608
0 PLC ± -	1 PLC ± -	2 PLC ± -	3 PLC ± 0.13[.005]	4 PLC ± -	ANGLES ± -
MATERIAL	FINISH	PRODUCT SPEC	APPLICATION SPEC	SIZE	CAGE CODE
				A1	00779
CUSTOMER DRAWING			SCALE 4:1	SHEET 1 of 1	REV S